

# NOVA

Stainless Steel  
Twin Wall Flue System



**NOVA® is British built** and specifically designed to meet the requirements for multi-functional applications serving both traditional negative draught appliance or modern high efficiency condensing appliances.



Manufactured in the UK



[www.sflchimneys.com](http://www.sflchimneys.com)



## ABOUT US

Sphering is the leading industrial player in flue and chimney systems in Europe.

**With +1000 experienced people across Europe, Sphering is an EU market maker with renowned expertise in design, manufacturing and distribution of advanced air and flue care systems.**



**+1000**  
Employees

**8**  
Production Plants

**26**  
Distribution Branches

## A UNIQUE COMBINATION OF LOCAL APPROACH AND GLOBAL EFFICIENCY

WE CARE TO DO WELL BY DOING GOOD

With customers

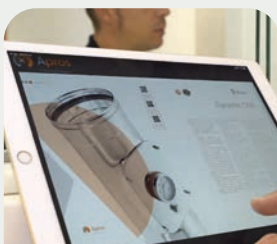

With employees

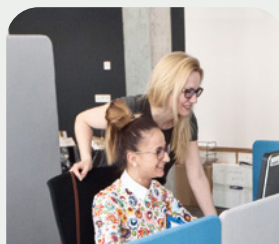

With secured and efficient product

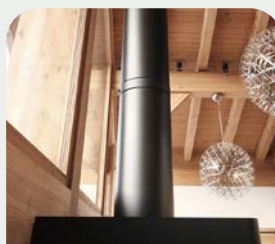

With the environment & society



EVERYTHING CHANGED IN 100 YEARS EXCEPT  
**OUR VALUES**

Staying loyal to its historical values and operating with an exclusive industrial model based on the autonomy of its brands, Sphering has become, in a century, an ethical industrial collider in Europe.

Since 1919  
**100** YEARS  
of passion



Reliable Partner



Leading Edge



Family long-term horizon



No Shortcut

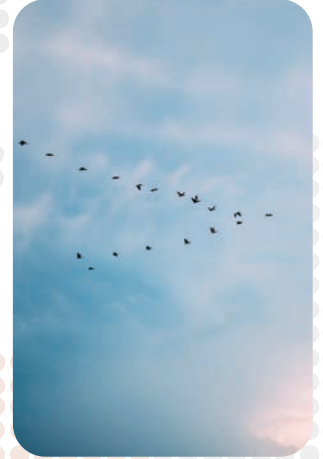

Local approach



**OUR R&D AND INNOVATION CENTERS**

We are here to stay and we collectively enable our capacity to answer our industry requirements.

**MORE THAN 150 TESTS PER YEAR**

These tests are based on requirements we have set up in order to guarantee our customers the highest levels of security and performance.



Thermal



Mechanical



Tightness



Fine dust

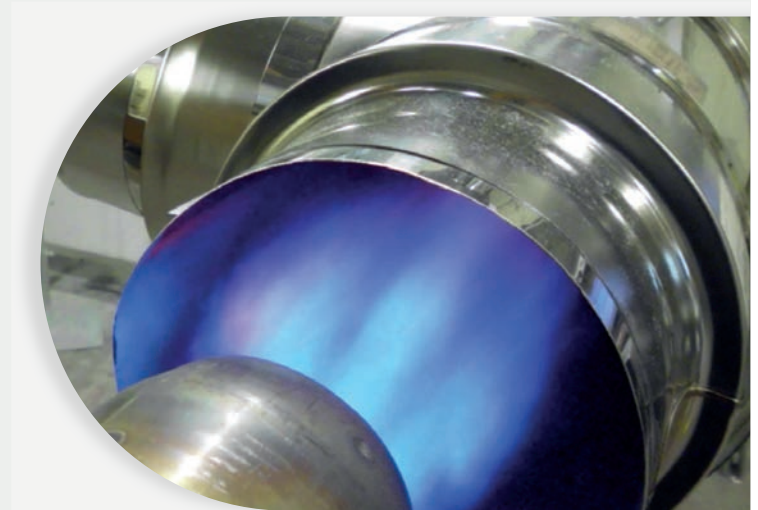

**DESIGN & TEST FOR MANUFACTURERS**

To ensure advanced safety, performance, quality and innovation.

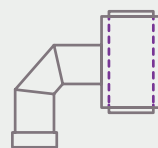

Special pieces co-development



Pairing test certification

# NOVA



Twin Wall Insulated  
Chimney System

**NOVA is a British built pre-fabricated twin-wall insulated stainless steel chimney system, CE and UKCA certified to BS EN 1856-1/2.**

**Suitable for condensing and positive pressure applications and is specifically designed to meet the demands of the latest high-efficiency heating appliances as well as traditional multi-fuel combustion equipment.**

NOVA is available in 8 internal diameters, ranging from 100mm to 355mm. With a wide range of components, together with a strong 16-barb twist-lock jointing system, NOVA offers the ultimate in ease of installation and functionality. With its strong joint design, NOVA can achieve a maximum unsupported height of 3.0 metres above the last support (2.0 m for DN100), without the need for structural locking bands.

As standard, NOVA is suitable for flue gas temperatures up to 600°C where the chimney is designed to operate under natural draught and dry conditions. With the addition of a retrofit elastomer seal, the range of application is extended, and the product is capable of positive pressure applications of up to 5000Pa(H1), subject to the performance characteristics given in Table A. This makes NOVA an ideal solution for condensing appliances and other applications where the chimney operates under positive pressure or wet condensing conditions.

NOVA XL extends the diameter range by a further 5 sizes, covering 400mm to 600mm internal diameter, please refer to separate NOVA XL brochure.



## Typical Applications

- Biomass
- Gas/Oil Boilers
- Micro CHP
- Pizza Ovens
- Bakery Ovens
- Coffee Roasters
- Fire Rated Compartments



British Built  
Flue System



Residential  
&  
Commercial



100-355mm  
Diameter



Twist-Lock  
Jointing System



Multi-Fuel  
Appliances



P1 / H1  
Rating



EI

Fire Rated  
EN1366-13



Approved  
Product



Year Product  
Warranty



Product &  
Downloads  
QR Code

UK  
CA | CE

Table A

NOVA Product Designations to BS EN 1856-1/2							
Standard Number	Diameter Range	Temperature Class	Pressure Class	D = Dry W = Wet	Corrosion Class	Material Specification Liner Grade 316L Liner Thickness 0.5	Sootfire Resistance G= Yes O= No
BS EN 1856-1	DN100 - DN355	T600	NI	D	V3	L50050	G(XX)
BS EN 1856-1	DN100-DN355	T450	NI	D	V3	L50050	G(XX)
BS EN 1856-1	DN100-DN355	T200	PI	W	V2	L50050	O(XX)
BS EN 1856-1	DN100-DN200	T160	HI	W	V2	L50050	O(XX)
BS EN 1856-2	DN100 - DN355	T450	NI	D	V3	L50050	G(XX)
BS EN 1856-2	DN100 - DN355	T200	PI	W	V2	L50050	O(XX)

**Notes**

1. PI & HI rating require elastomer seals to be fitted.
2. Distance to combustible material (XX) - DN100-DN300 = 50mm DN355 = 75mm
3. With the exception of T600 all other designations have been tested within a combustible enclosure. T600 is only rated for unenclosed application in an open environment.

**Approvals**

NOVA is CE and UKCA certified to BS EN 1856-1/2, certificate no. 2797-CPR-496040, 2797-CPR-559419 and 0086-CPR740592, 0086-CPR-740593 respectively to the performance designations as detailed in Table A above.

**Fire Resistance**

NOVA has been tested to BS EN 1366-13 Fire Resistance Tests for Service Installations (Chimneys) achieving the following classification to BS EN 13501-2.

**EI 90 (i→o) h<sub>o</sub> v<sub>e</sub> Type A**

The integrity has also been assessed for a period of 4 hours under the general principles of BS 476 Part 20.

**Quality**

All components are manufactured under a Quality Management System, certificate No. FM557622, administered by British Standards in accordance with BS EN 9001:2015.

**Construction**

NOVA is fabricated with a laser welded 0.5mm 316L (1.4404:X2CrNiMo 17-12-2) stainless steel inner liner and a grade 304 (1.4301:X5CrNi18-10) outer case. The product features a high-performance insulation that is auger injected into the 25mm annulus to a density of 250Kg/m<sup>3</sup>, offering rapid stabilisation of draught and thermal performance. The unique joint design allows in inner liner to expand and contract throughout the system, eliminating the need for additional expansion components.

Condensate and pressure resistance, if the application demands, is achieved using a retrofit three lip elastomer seal located in the liner of the male end. The joint is finished with a locking band supplied as standard with the component.

**Warranty**

NOVA is backed by a comprehensive 20-year manufacturing defects warranty. The 20-year warranty is a measure of our confidence in the manufactured quality and installed reliability of our flue systems and gives added peace of mind for any installation.

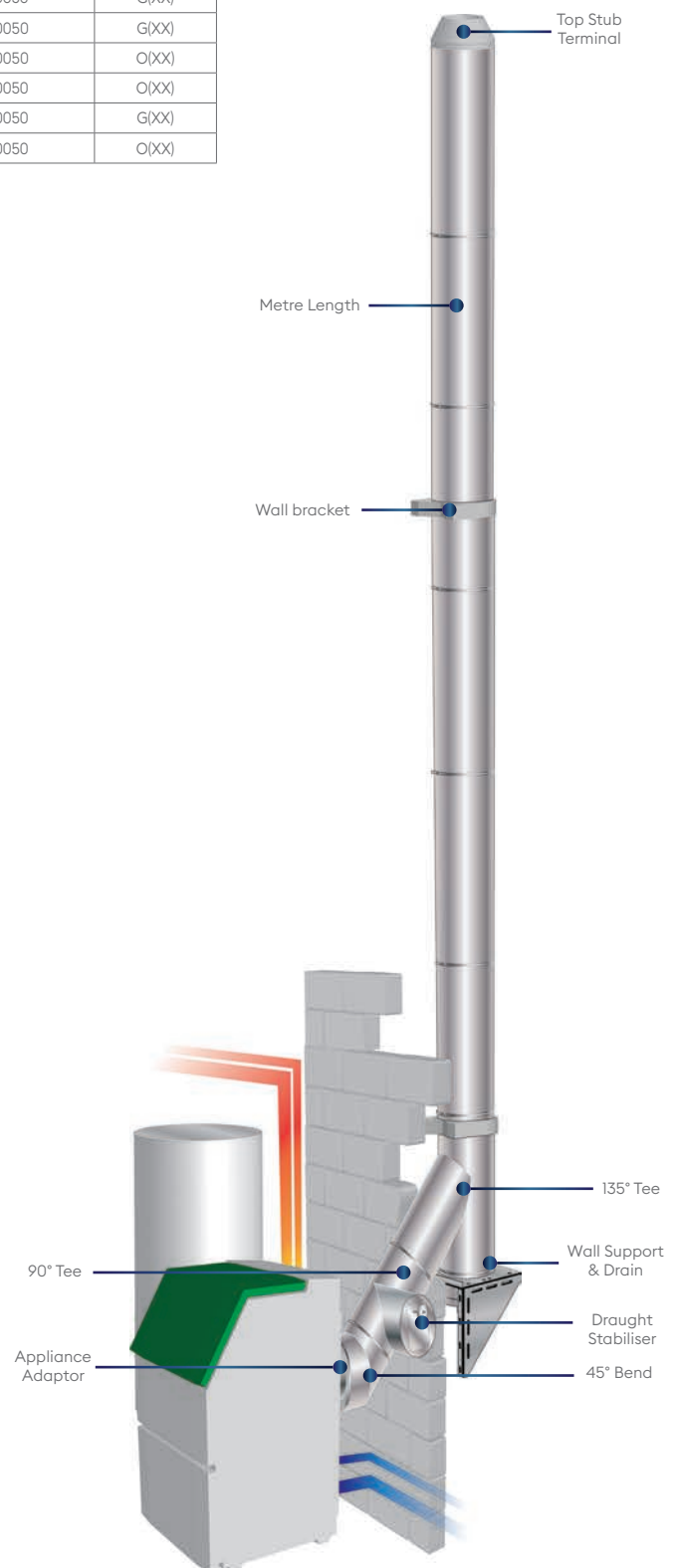

**IMPORTANT (Always Read The Installation Instructions)**

For detailed information regarding design, installation and application of this product, please refer to the separate installation instructions available on the website which can also be accessed from the QR code.

**Partner with us, succeed together.**

Need assistance with your residential or commercial flue project? Our team of experienced experts is here to help at every stage. We offer product selection and design assistance, conduct system surveys, and work with key installation partners to provide bespoke turnkey packages tailored to your needs.

www.sflchimneys.com  
info@sflchimneys.com  
01271 326633

# Adaptor

# NOVA

## Appliance Adaptor

Used to connect the appliance outlet to the NOVA chimney system. This adaptor is also used for connection of the draught regulator to the branch of a 90° tee.

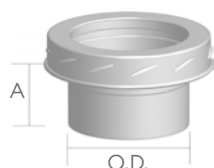

Ø	Dim A	O.D.	Code
100mm	63	98	4578504N
130mm	63	128	4578505N
150mm	63	148	4578506N
180mm	63	178	4578507N
200mm	63	198	4578508N
250mm	63	248	4578510N
304mm	63	298	4578512N
355mm	63	348	4578514N

## Appliance Adaptor (Imperial)

Used for connection to appliances with imperial or equivalent spigots.

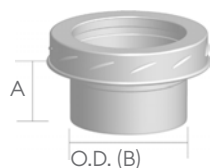

Ø	A	B	Code
130mm	63	125mm	4578405N
180mm	63	175mm	4578407N

## Appliance Increaser Adaptor

Used to increase the appliance outlet size by one diameter.



Ø	O.D. (A)	Code
100mm	80mm	4579404N
150mm	123mm	4579505N
150mm	130mm	4579405N

## SUPRA PLUS to NOVA Adaptor

Used to connect from the SUPRA PLUS chimney system or for use as an appliance adaptor.



Ø	Code
100mm	4179610
130mm	4179613
150mm	4179615
180mm	4179618
200mm	4179620
250mm	4179625
304mm	4179630
355mm	4179635

## NOVA to SUPRA PLUS Adaptor

Designed to facilitate connection from the NOVA to SUPRA PLUS chimney system.

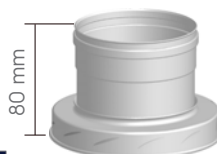

Ø	Code
100mm	4179610
130mm	4179613
150mm	4179615
180mm	4179618
200mm	4179620
250mm	4179625
304mm	4179630
355mm	4179635

## NOVA to Flex Adaptor

Used to connect the NOVA product to a generic flexible flue liner. Supplied with clamp band for ease of installation.

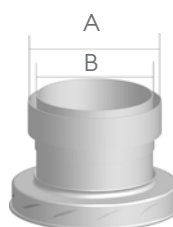

Ø	A	B	Code
100mm	113	96	4573404N
130mm	136	121	4573405N
150mm	163	146	4573406N
180mm	193	171	4573407N
200mm	213	196	4573408N
250mm	263	246	4573410N
304mm	313	296	4573412N
355mm	370	346	4573414N

## Flex to NOVA Adaptor

Used to connect a generic flexible flue liner to NOVA, e.g. where a masonry chimney has been capped within a roof void. Supplied with clamp band for ease of installation.



Ø	A	B	Code
100mm	113	96	4573204N
130mm	136	121	4573205N
150mm	163	146	4573206N
180mm	190	171	4573207N
200mm	213	196	4573208N
250mm	263	246	4573210N
304mm	313	296	4573212N
355mm	370	346	4573214N

# Lengths

# NOVA

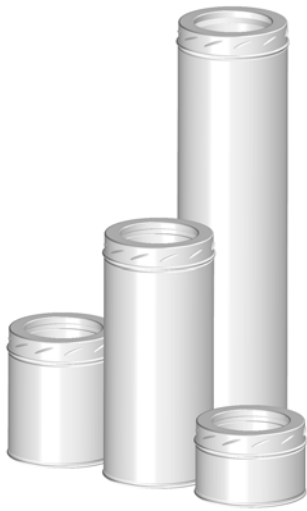

## Straight Lengths

Available in nominal installed lengths of 1500mm, 1000mm, 500mm, 250mm & 120mm.

Ø	Installed Length			
	120mm Code	250mm Code	500mm Code	1000mm Code
100mm	4575304N	4571904N	4575104N	4575004N
130mm	4575305N	4571905N	4575105N	4575005N
150mm	4575306N	4571906N	4575106N	4575006N
180mm	4575307N	4571907N	4575107N	4575007N
200mm	4575308N	4571908N	4575108N	4575008N
250mm	4575310N	4571910N	4575110N	4575010N
304mm	4575312N	4571912N	4575112N	4575012N
355mm	4575314N	4571914N	4575114N	4575014N

1500mm	
150mm	4579906N



## Adjustable Lengths

The adjustable length offers a degree of flexibility when standard length dimensions are not suitable. All adjustable lengths are supplied with separate insulating material for insertion into the annulus once the installed length has been determined. Where adjustable lengths are required for positive pressure and condensate resistance, two seals are required per component.

Ø	Short (210mm - 320mm) Code	Long (310mm - 500mm) Code	Seal
100mm	4576604N	4574604N	4006310
130mm	4576605N	4574605N	4006313
150mm	4576606N	4574606N	4006315
180mm	4576607N	4574607N	4006318
200mm	4576608N	4574608N	4006320
250mm	4576610N	4574610N	4006325

Ø	Short (255mm - 410mm)	Long (330mm - 550mm)	Seal
304mm	4576612N	4574612N	4006530
355mm	4576614N	4574614N	4006535

Note: As the insulation density is installed on site and not controlled by SFL, it is recommended that this component is located at least 300mm from any combustible material.

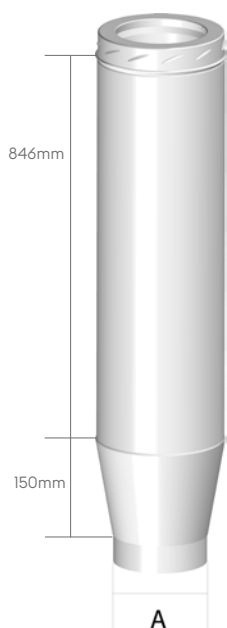

## Starter Lengths

Designed to offer an aesthetic transition from the connecting flue pipe to the NOVA chimney system.

Ø	A (mm) O.D	Code
130mm	125mm	4570405N
150mm	150mm	4570406N
180mm	175mm	4570407N
200mm	200mm	4570408N

Note: This component is not designed for direct connection to the appliance.



## Adjustable Slip Lengths

The adjustable slip length is designed to be used with an existing length and allows for a smaller range of adjustment from 48mm - 295mm, depending on diameter. Once installed, insulation blankets are applied around the joint and finished with a cover band.

Ø	Code
100mm	4570004N
130mm	4570005N
150mm	4570006N
180mm	4570007N
200mm	4570008N
250mm	4570010N

*Note: As the insulation density is installed on site and not controlled by SFL, it is recommended that this component is located at least 300mm from any combustible material.*

## Inspection Length - (P1/W)

Use to provide access for inspection and cleaning. To be used for positive pressure and wet systems where the flue gases are likely to condensate within the chimney system. Suitable for flue gas temperatures up to 200°C at 200Pa. Where use for higher temperature applications the internal seal MUST be removed.

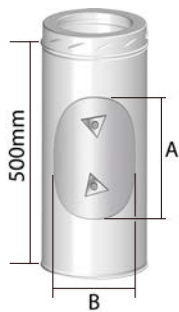

Ø	Dims (mm)		Code
	A	B	
100mm	206	70	4576304N
130mm	206	80	4576305N
150mm	215	100	4576306N
180mm	215	100	4576307N
200mm	215	100	4576308N
250mm	215	100	4576310N
304mm	215	100	4576312N
355mm	215	100	4576314N

## Duct Drain Length

Used in an inclined position to trap condensate and permit drainage. It is fitted with a standard stainless steel BSP thread connection and incorporates an internal back flow dam.



Ø	Dim A	Code
100mm	1" BSP	4576804N
130mm	1" BSP	4576805N
150mm	1" BSP	4576806N
180mm	1" BSP	4576807N
200mm	1" BSP	4576808N
250mm	1" BSP	4576810N
304mm	1" BSP	4576812N
355mm	1" BSP	4576814N



## Probe Length

Supplied with a M16 threaded washer and bolt to facilitate a commissioning sampling probe. Cover jacket supplied to cover sampling point when not in use.

Ø	Code
100mm	4576704N
130mm	4576705N
150mm	4576706N
180mm	4576707N
200mm	4576708N
250mm	4576710N
304mm	4576712N
355mm	4576714N

## Damper Length (P1/W)

Use for balancing multi-inlet systems and to add resistance. Also suitable for wet systems.



Ø	Code
100mm	4574004N
130mm	4574005N
150mm	4574006N
180mm	4574007N
200mm	4574008N
250mm	4574010N
304mm	4574012N
355mm	4574014N





## 2 Segment Elbows (15°, 30°, 40°, 45°)

Provides a change of direction, measured from the vertical by the specified angle. Refer to Installation Instructions for dimensions. Elbows are supplied with an unbarbed female coupler to allow full 360° rotation and a screw-toggle type locking band for additional strength.

Ø	Code			
	15° Code	30° Code	40° Code	45° Code
100mm	4575404N	4575504N	4575604N	4575704N
130mm	4575405N	4575505N	4575605N	4575705N
150mm	4575406N	4575506N	4575606N	4575706N
180mm	4575407N	4575507N	4575607N	4575707N
200mm	4575408N	4575508N	4575608N	4575708N
250mm	4575410N	4575510N	4575610N	4575710N
304mm	4575412N	4575512N	4575612N	4575712N
355mm	4575414N	4575514N	4575614N	4575714N

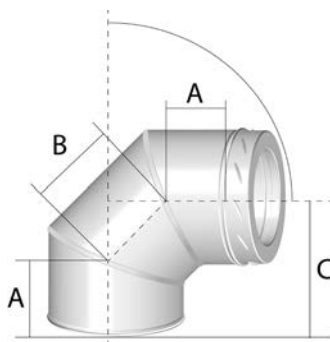

## Three-segment 90°, 85° & 87° Elbows

Provides a change of direction measured from the vertical. Use 85° and 87° for condensing applications where a 5° or 3° incline (respectively) to the horizontal is required for condensate drainage.

Ø	Dimension (mm)			85° Code	Dimension (mm)			87° Code
	A	B	C		A	B	C	
100mm	91	126	192	4575804N	91	126	185	4574904N
130mm	98	136	207	4575805N	98	136	200	4574905N
150mm	102	144	217	4575806N	102	144	210	4574906N
180mm	108	156	233	4575807N	108	156	226	4574907N
200mm	112	165	244	4575808N	112	165	236	4574908N
250mm	123	185	270	4575810N	123	185	262	4574910N
304mm	132	217	297	4575812N	132	217	291	4574912N
355mm	140	235	318	4575814N	140	235	312	4574914N

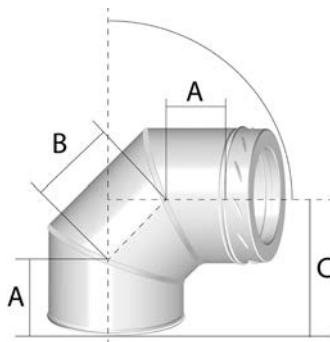

90° Elbow

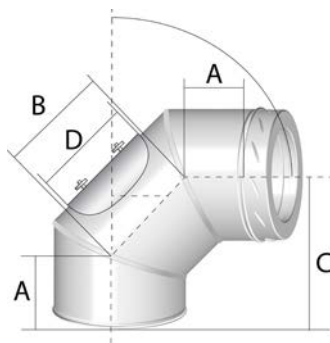

Inspection Elbow

Ø	Dimension (mm)			90° Code	Inspection Elbow				90° Code
	A	B	C		A	B	C	D	
100mm	91	126	180	4575904N	91	272	283	180	4576104N
130mm	98	136	193	4575905N	98	272	290	180	4576105N
150mm	102	144	204	4575906N	102	282	301	200	4576106N
180mm	108	156	219	4575907N	108	282	307	200	4576107N
200mm	112	165	229	4575908N	112	282	311	200	4576108N
250mm	123	185	254	4575910N	123	282	322	200	4576110N
304mm	132	217	285	4575912N	133	282	332	200	4576112N
355mm	140	235	306	4575914N	143	282	342	200	4576114N

# Increasers

# NOVA

## Increaser

Facilitates an increase in diameter by one size. Constructed with a smooth conical design and welded seams to prevent the build-up of condensates.

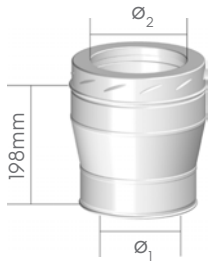

$\varnothing_1$	$\varnothing_2$	Code
100mm	130	4573604N
130mm	150	4573605N
150mm	180	4573606N
180mm	200	4573706N
200mm	250	4573608N

## Eccentric Increaser

Designed specifically for condensing applications to provide an increase in diameter without pooling of condensation in horizontal or inclined runs.

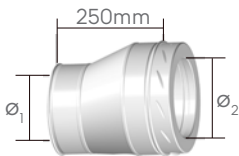

$\varnothing_1$	$\varnothing_2$	Code
150mm	200mm	4570606N
180mm	250mm	4570607N
200mm	250mm	4570608N
200mm	304mm	4570708N
250mm	304mm	4570610N
250mm	355mm	4570710N

# Tee Components

## Locking Plug

Used to close off the branch or base of a tee or for use as an access/inspection component.

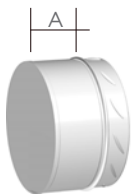

$\varnothing$	Dims (mm)		Code
	A	B	
100mm	206	70	4576304N
130mm	206	80	4576305N
150mm	215	100	4576306N
180mm	215	100	4576307N
200mm	215	100	4576308N
250mm	215	100	4576310N
304mm	215	100	4576312N
355mm	215	100	4576314N

## Condensate Collector

Used at the bottom of a vertical chimney to facilitate the drainage of condensate from the system. Fitted with a stainless steel BSP external thread drain connection. Supplied with BSP cap protector.

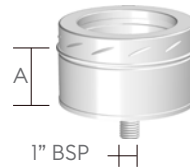

$\varnothing$	A	Code
100mm	63	4576904N
130mm	63	4576905N
150mm	63	4576906N
180mm	63	4576907N
200mm	63	4576908N
250mm	63	4576910N
304mm	63	4576912N
355mm	63	4576914N

## Draught Regulator

Dual action draught regulator suitable for multi fuel applications. Designed to be used with SFL chimney systems where excessive draught is likely to create combustion problems. When used with the NOVA chimney system, the regulator should be applied with the 45785XXN appliance adaptor (in turn located onto the 90° tee branch).

$\varnothing$	Code
100mm	3192004
130mm	3192005
150mm	3192006
180mm	3192007
200mm	3192008
250mm	3192010
304mm	3192012
355mm	3192014

*Note: The above draught regulator is not suitable for explosion relief. Please contact SFL for alternative models.*

## 90°, 93° & 95° Equal Tee

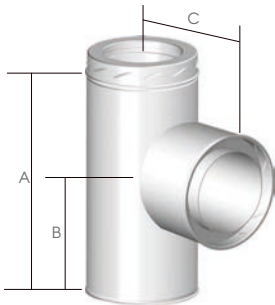

### Equal Tees

Equal tees are available in 90°, 93° and 95° options. Mainly used at the base of a vertical chimney to allow drainage, manifold headers, or inspection points. The 93° and 95° options are mainly used in condensing systems to allow either a 3° or 5° fall, allowing condensation to drainage back through the system to a suitable drainage point.

Ø	Dimensions			Standard Tees - Code		
	A	B	C	90° Code	93° Code	95° Code
100mm	300	180	140	4573004N	4573304N	4576404N
130mm	330	195	155	4573005N	4573305N	4576405N
150mm	350	205	165	4573006N	4573306N	4576406N
180mm	380	220	180	4573007N	4573307N	4576407N
200mm	400	230	190	4573008N	4573308N	4576408N
250mm	450	255	215	4573010N	4573310N	4576410N
304mm	500	265	240	4573012N	4573312N	4576412N
355mm	550	305	270	4573014N	4573314N	4576414N

## 90° & 95° Reducing Tees

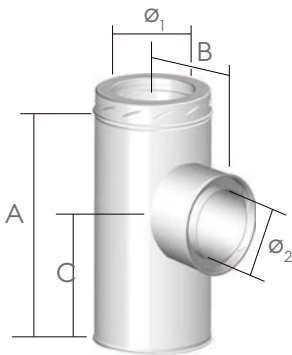

### 90° & 95° Reducing Tee

A wide variety of reducing tee combinations are available. Listed below are the most common single-step reductions, i.e. 150mm body, 130mm branch. For a full range of available reducing tees, please speak to SFL Technical Sales.

Ø <sub>1</sub>	Dimensions					Code	
	Ø <sub>2</sub>	A	B	C 90°	C 95°	90° Reducing Tee	95° Reducing Tee
100mm	300	533	133	266	287	-	-
130mm	330	533	148	266	287	4559001	4559501
150mm	350	533	158	266	287	4559003	4559503
180mm	380	533	173	266	287	4559011	4559511
200mm	400	533	183	266	287	4559021	4559521
250mm	450	533	208	266	287	4559028	4559528
304mm	500	533	235	266	287	4559034	4559534
355mm	550	533	260	266	287	4559041	4559541

## 135° Tee & Elbow

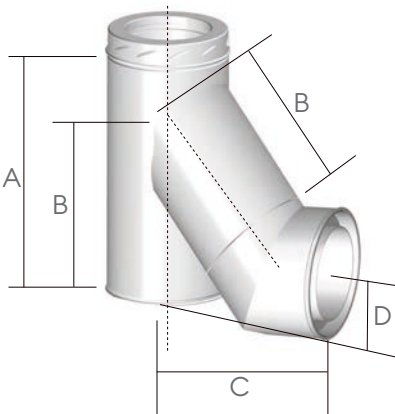

### 135° Tee

Used at the base of a vertical chimney, or to allow a smooth transition from the horizontal to vertical plain when used with a 45° elbow. The coupler on the branch is unbarbed to allow unlimited rotational adjustment and provided with an adjustable screw-toggle locking band.

Ø	Dimension (mm)						Code
	135° Tee		With 40° Elbow		With 45° Elbow		
	A	B	C	D	C	D	
100mm	495	325	385	23	385	31	4576504N
130mm	495	340	407	22	407	30	4576505N
150mm	495	375	439	29	439	38	4576506N
180mm	745	420	481	37	481	47	4576507N
200mm	745	450	509	43	509	53	4576508N
250mm	745	520	577	55	577	65	4576510N
304mm	745	585	625	73	625	84	4576512N
355mm	995	650	688	84	688	96	4576514N

# Made To Measure Components

# NOVA

## Specials for NOVA

Although NOVA offers an extensive range of components, SFL understands that there are times when a standard component will simply not work for the intended installation.

Being a UK manufacturer, we are ideally placed to manufacture bespoke components in a timely and competitive manner. Please photocopy and complete the required dimensions for the required special component and email your requirements to SFL Technical Services Dept, who will be happy to offer a quotation and lead time.

### Appliance Adaptors

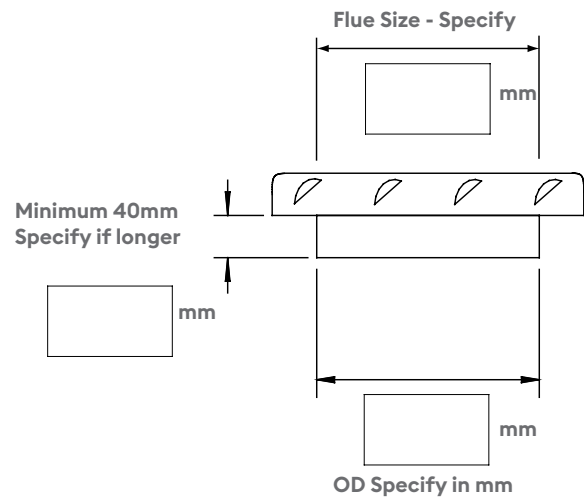

### For Standard 90° & 95° Reducing Tees

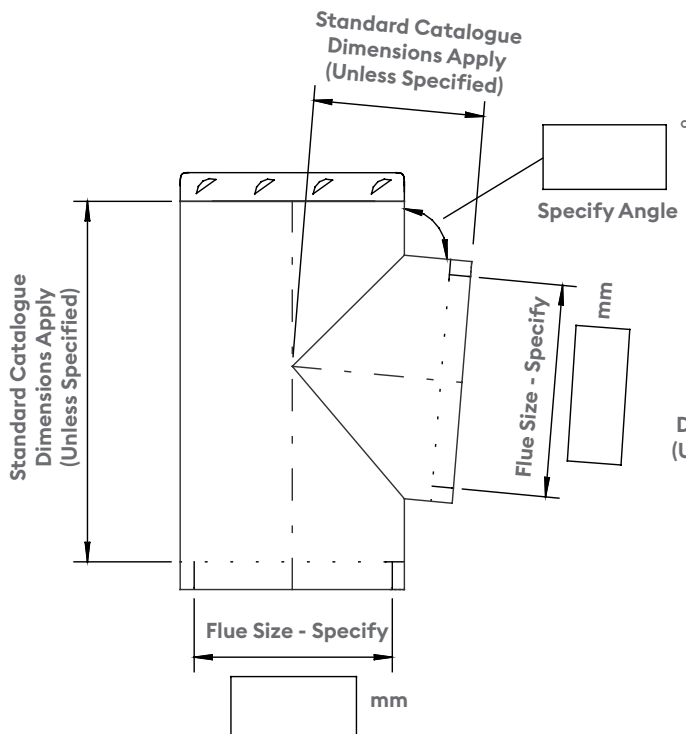

### Elbows

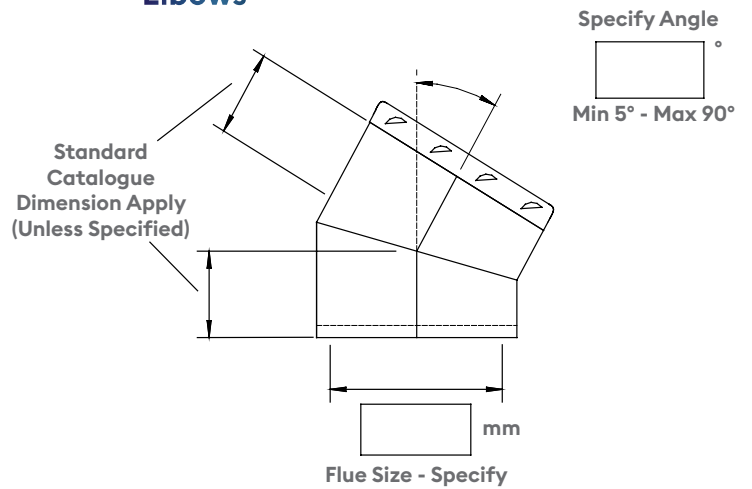

Customer Name
Customer Address
Telephone Number
Email Address
Comments

## Roof / Rafter Support

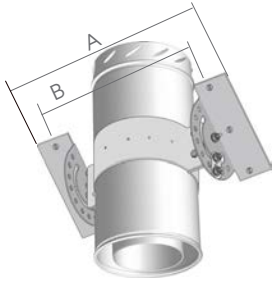

Provided with adjustable gimbal plates to permit a chimney to be supported on roof joists, trussed rafters etc. Maximum suspended chimney length supported is 6.0 metres and maximum total length supported is 9.0 metres.

∅	A	B	Code
100mm	418	310	7072610
130mm	448	340	7072613
150mm	468	360	7072615
180mm	498	390	7072618
200mm	518	410	7072620
250mm	568	460	7072625
304mm	618	510	7072630
355mm	668	560	7072635

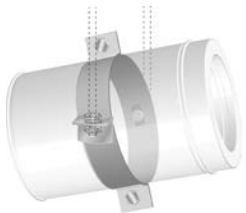

## Universal Split Band

Offers lateral support to the chimney system. The split band has adjustable brackets to allow the support of inclined runs. Design for use with M10 Drop Rod.

∅	Code
100mm	3123150
130mm	3123180
150mm	3123200
180mm	3123230
200mm	3123250
250mm	3123300
304mm	3123350
355mm	3123400



## Single Wall to NOVA Anchor Plate

Designed to be used when connecting NOVA to a lintel or pre-cast chamber. A short section of liner projects a nominal 32mm through the bottom of the plate. Installed length "H" is 40mm while "E" is 27mm and there are 8 x 11mm fixing holes at the centres shown in the table below. Manufactured in stainless steel. Maximum Load: 13m.

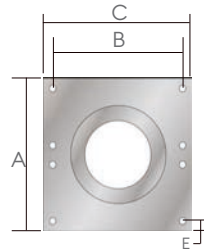

∅	A	B	C	Code
100mm	281	196	252	4577504N
130mm	311	226	282	4577505N
150mm	331	246	302	4577506N
180mm	360	275	331	4577507N
200mm	384	299	355	4577508N
250mm	432	345	403	4577510N
304mm	482	395	453	4577512N
355mm	533	446	504	4577514N

For loading details and maximum distance between supports, please refer to the Installation Instructions.

## Support length (Strut/Guy Attachment)



A 117mm installed length which incorporates a plate located 33mm from the bottom edge and features slotted holes for rotational adjustment. This component also doubles as a strut / guy attachment length offering anchoring points to which guys, or preferably rigid stays can be secured using M8 nuts and bolts. Manufactured from stainless steel.

∅	Code
100mm	4578804N
130mm	4578805N
150mm	4578806N
180mm	4578807N
200mm	4578808N
250mm	4578810N
304mm	4578812N
355mm	4578814N



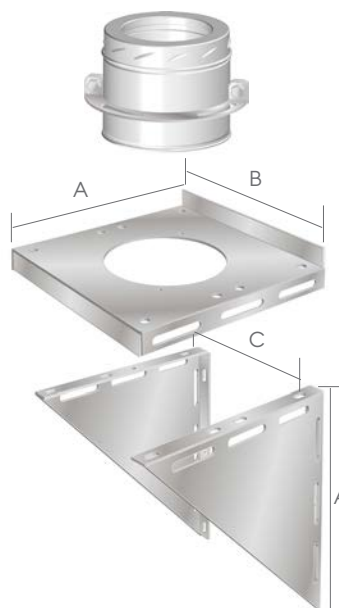

## Wall Support Bracket

Used to take the vertical load of the chimney when supported from a wall. The support bracket is fully adjustable allowing varying clearances from the wall (50mm as standard). Requires M10 wall fixings.

∅	A	B	C	Stainless Code	Galvanised Code
100mm	252	281	235	4572304	4572204
130mm	282	311	265	4572305	4572205
150mm	302	331	285	4572306	4572206
180mm	331	360	314	4572307	4572207
200mm	355	384	338	4572308	4572208
250mm	403	432	384	4572310	4572210
304mm	453	482	434	4572312	4572212
355mm	504	533	485	4572314	4572214

A For loading details and maximum distance between supports, please refer to the Installation Instructions.

## Universal Support Plate

A support plate designed for use with bespoke bracketry such as Uni-Strut/Niessing or site fabricated. Supplied complete with a Support Length. Fixing hole size 11mm to suit M10 fixings.

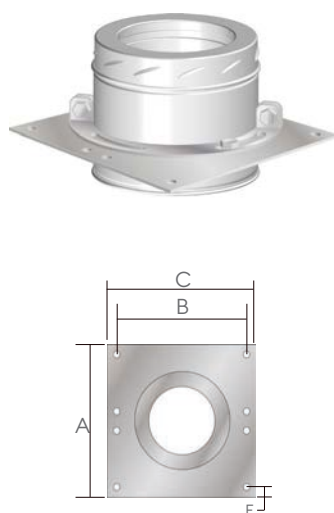

∅	A	B	C	Max Load	Stainless Code	Galvanised Code
100mm	281	196	252	13m	4571704N	4571404N
130mm	311	226	282	13m	4571705N	4571405N
150mm	331	246	302	13m	4571706N	4571406N
180mm	360	275	331	13m	4571707N	4571407N
200mm	384	299	355	13m	4571708N	4571408N
250mm	432	345	403	13m	4571710N	4571410N
304mm	482	395	453	13m	4571712N	4571412N
355mm	533	446	504	13m	4571714N	4571414N

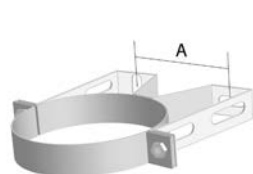

## Standard Wall Bands

Wall bands provide lateral support for the chimney and must be used at intervals not exceeding 4.0 metres beyond any load bearing support.

## Wall Band Extension Pieces

Used with Wall Bands, these components allow the clearance between the wall and outer surface of the chimney to be increased. Where externally applied, the intervals between Wall Band fixing centres must be reduced from 4.0 metres to 3.5 metres. The maximum clearance is as detailed below.



∅	Dim	Stainless Code	Galvanised Code	Extension (mm)		Stainless Code	Galvanised Code
	A			Min	Max		
100mm	112	3115154	3116154	65	105	3119136	3120136
130mm	142	3115185	3116185	50	100	3119136	3120136
150mm	162	3115205	3116205	50	100	3119136	3120136
180mm	192	3115234	3116234	50	100	3119136	3120136
200mm	212	3115255	3116255	50	100	3119136	3120136
250mm	266	3115305	3116305	50	100	3119180	3120180
304mm	316	3115355	3116355	75	140	3119245	3120245
355mm	366	3115405	3116405	50	120	3119245	3120245

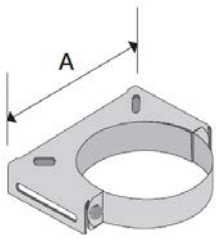

## Heavy Duty Wall Band

Can be used where additional bracing is required or used with Extension Brackets to increase the clearance from the building, e.g. for offsets. Supplied with nut inserts for easy installation.

Ø	A	Code
100mm	220	3109510
130mm	250	3109513
150mm	270	3109515
180mm	300	3109518
200mm	320	3109520
250mm	370	3109525

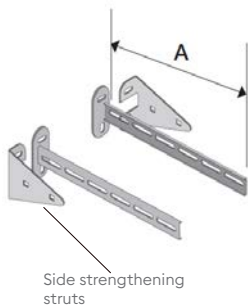

## Extension Brackets

Available in Short, Medium and Long versions to offer greater flexibility. Extension Brackets can only be used with the Heavy Duty Wall Band. The Extension Brackets can be cut to length on site if required. The side strengthening struts must be used where the clearance exceeds 200mm.

Size	A	Code
Short	324	31093ST
Medium	395	31093MD
Long	600	31093LG

### Maximum/minimum distances for wall bands and extension arms:

Ø	Max SHORT	Max MEDIUM	Max LONG	Min with Arms	Min without Extension Arms
100mm	249	320	525	55mm	50mm
130mm	234	305	510	55mm	50mm
150mm	224	295	500	55mm	50mm
180mm	209	280	485	55mm	50mm
200mm	199	270	475	55mm	50mm
250mm	174	245	450	55mm	50mm

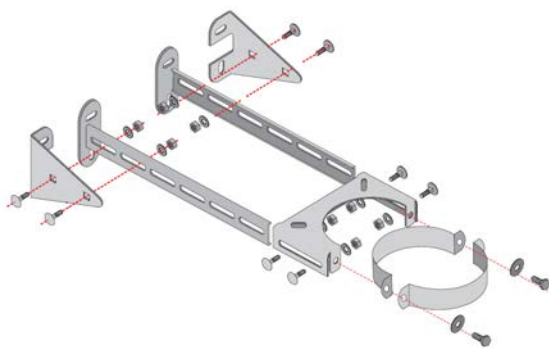

## Universal Roof Bracing Bracket

Used to offer additional lateral bracing above the roof level. Ideal when installing offsets around fascia boards or where higher termination heights are required. The telescopic legs are adjustable between 1650mm - 2900mm, while the clamp band features nut inserts for ease of installation.

Ø	A	Code
100mm	150	7073310
130mm	180	7073313
150mm	200	7073315
180mm	227	7073317
200mm	250	7073320
250mm	300	7073325

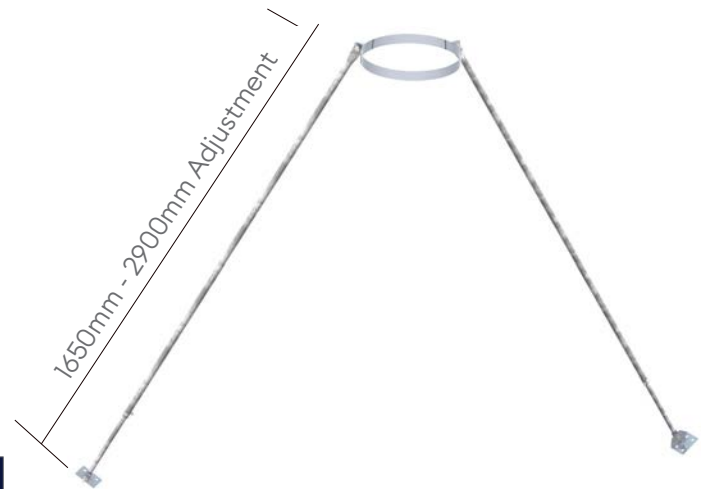

# Floor & Ceiling Penetrations

# NOVA

## Gas and oil appliance (T250)

The following components MUST be used on gas or oil fired appliances where the flue gas temperatures does not exceed 250°C and / or where the chimney passes through a non-combustible floor.

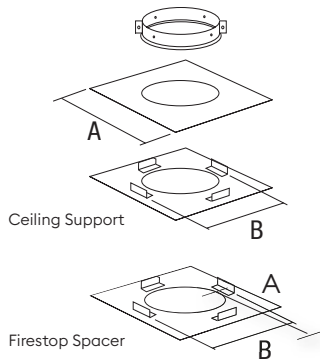

## Ceiling Support

Provides a 50mm air gap clearance to a penetrated floor or ceiling and is only used where NOVA penetrates a non-combustible floor, and / or services a gas or oil fired appliance where the flue gas temperature does not exceed 250°C

## Firestop Spacer

Used to provide location, fire and dust stopping where NOVA is used through non-combustible floors, and / or serves a gas or oil fired appliance where the flue gas temperatures does not exceed 250°C. This item does not load bear.

ø	Dimension (mm)		Code	Dimension (mm)		Code
	A	B		A	B	
100mm	300	250	4502704	300	250	4508704
130mm	330	280	4502705	330	280	4508705
150mm	355	305	4502706	355	305	4508706
180mm	381	331	4502707	381	331	4508707
200mm	406	356	4502708	406	356	4508708
250mm	457	407	4502710	457	407	4508710
304mm	507	457	4502712	507	457	4508712
355mm	558	508	4502714	558	508	4508714

## Solid fuel and oil fire appliance (T450)

The following components MUST be used where NOVA is used on solid fuel or oil fired appliances where the flue gas temperature will not exceed 450°C and /or where the chimney system penetrates a combustible floor. Each ventilated component offers a 50mm clearance to combustible materials.

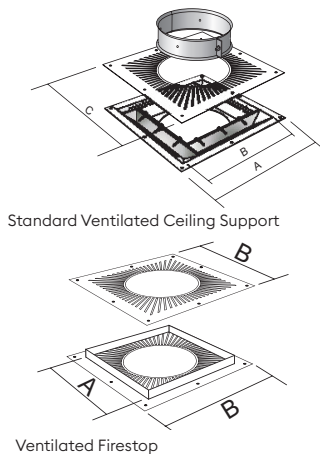

## Standard Ventilated Ceiling Support (T450)

Used to both support and fire stopping the chimney system when it passes through the first combustible floor directly above the appliance. The support component incorporates a patented intumescent matrix design which expands rapidly with temperature and seals the plate to prevent the potential spread of fire or smoke from the room below.

## Ventilated Firestop (T450)

Used where the chimney passes through the upper combustible floors and where sections below the floor are enclosed within a non combustible shaft. This item does not load bear.

ø	Dim (mm)			Code	Dim (mm)		Code
	A	B	C		A	B	
100mm	331	251	349	7072710	251	349	5508310
130mm	361	281	379	7072713	281	379	5508313
150mm	381	301	399	7072715	301	399	5508315
180mm	411	331	429	7072718	331	429	5508318
200mm	431	351	453	7072720	351	453	5508320
250mm	481	401	501	7072725	402	501	5508325
304mm	531	451	551	7072730	452	551	5508330

For painted variations add the following letters after the part number:- White: ZW

## D5 Ventilated Ceiling Support (T450)

Used as per the standard version. The D5 offers an aesthetically pleasing flat appearance where the chimney passes through the ceiling penetration and has minimal ventilation openings. This component is finished in a high quality white powder coated finish.

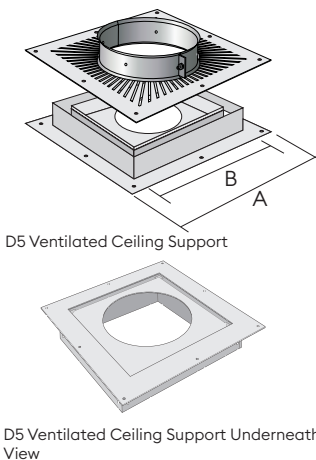

ø	A	B	Code
100mm	322	249	7072810ZW
130mm	352	279	7072813ZW
150mm	372	299	7072815ZW
180mm	402	329	7072818ZW
200mm	422	349	7072820ZW

For installation information concerning floor penetrations, please refer to the products separate Installation Instructions.

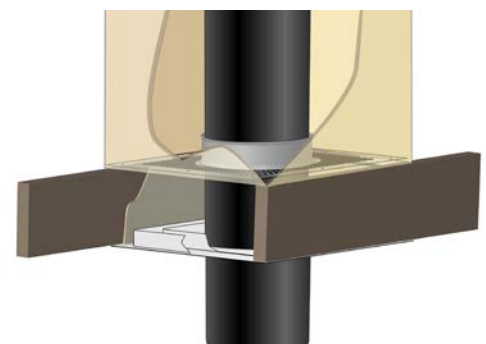



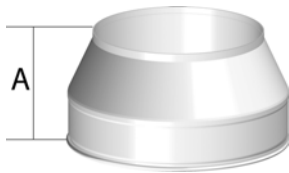

### Top Stub

The Top Stub terminal offers the least resistance to flue gas and is ideal for solid fuel and oil-fired appliances, providing there is drainage at the base of the chimney.

### Top Stub With Mesh

Ideally suited for condensing/high efficiency appliances. Not suitable for solid fuel application or where there is no provision for drainage below termination.

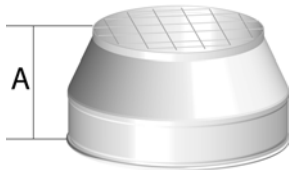

ø	Dimension (mm)		Code	Dimension (mm)	
	A			A	Code
100mm	100		4570804	100	4570704
130mm	100		4570805	100	4570705
150mm	100		4570806	100	4570706
180mm	100		4570807	100	4570707
200mm	100		4570808	100	4570708
250mm	100		4570810	100	4570710
304mm	100		4570812	100	4570712
355mm	100		4570814	100	4570714

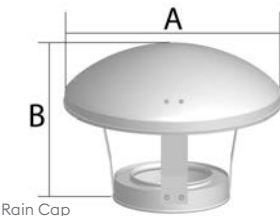

### Rain Cap

The Rain Cap offers a degree of protection from rain and is suitable for solid fuel and oil-fired appliances.

### Round Top

The Round Top offers a greater degree of protection against driving rain and wind and is recommended for exposed locations.

Rain Cap

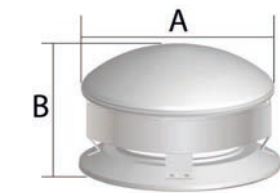

Round Top

ø	Dim (mm)		Code	Dim (mm)		Code
	A	B		A	B	
100mm	255	192	4577304	255	155	4573104
130mm	255	197	4577305	300	159	4573105
150mm	300	204	4577306	300	157	4573106
180mm	358	265	4577307	358	189	4573107
200mm	402	265	4577308	402	194	4573108
250mm	500	300	4577310	500	253	4573110
304mm	716	345	4577312	716	288	4573112
355mm	716	385	4577314	716	356	4573114

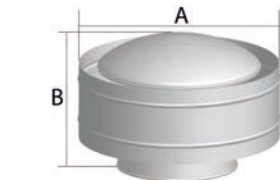

### Storm Cowl

The Storm Cowl is designed to offer maximum protection against driving rain and strong winds. Please note that this is not an anti-down draught terminal.

### Storm Cowl with Mesh

As Storm Cowl but for gas fired applications, not suitable for use on solid fuel.

ø	A	B	Code	A	B	Code
100mm	270	165	4578704	270	165	4578904
130mm	294	165	4578705	294	165	4578905
150mm	319	165	4578706	319	165	4578906
180mm	344	165	4578707	344	165	4578907
200mm	369	165	4578708	369	165	4578908
250mm	419	210	4578710	419	210	4578910



### NOVA Mini EUROCOWL

The NOVA-specific version of the most popular anti-down draught cowl on the market, complete with a factory-fitted NOVA female coupler and locking band for effortless and secure installation.

ø	Code
125mm	4574505N
150mm	4574506N

# Flashings & Weathering

# NOVA

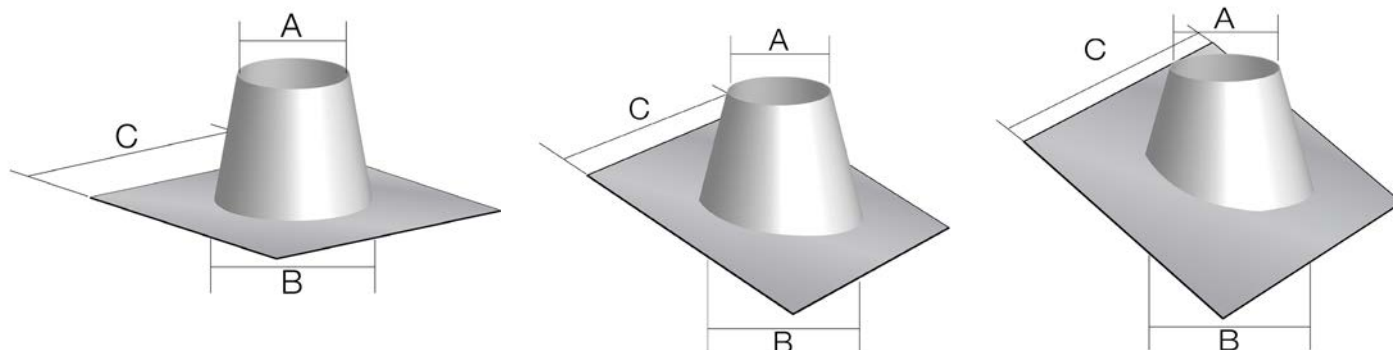

## Aluminium Flashings

The SFL aluminium flashing range offers a competitive alternative to the traditional lead flashing, while still maintaining a traditional design and malleable material. All aluminium flashings require a Storm Collar

### Flat Flashing

For flat or nearly flat roofs.

### 5° – 30° Adjustable Flashing

For low pitched roofs.

### 32° – 45° Adjustable Flashing

For high pitched roofs.

Ø	Dimension (mm)											
	A	B	C	Code	A	B	C	Code	A	B	C	Code
100mm	160	250	495	70000006	160	250	495	70053006	160	332	660	70324506
130mm	190	280	495	70000007	190	280	495	70053007	190	375	660	70324507
150mm	210	300	495	70000009	210	300	660	70053009	210	403	660	70324509
180mm	235	325	660	70000010	235	325	660	70053010	235	440	820	70324510
200mm	260	350	660	70000011	260	350	660	70053011	260	475	820	70324511
250mm	310	400	660	70000012	310	400	660	70053012	310	546	820	70324512
304mm	360	450	660	70000013	360	450	820	70053013	360	617	820	70324513
355mm	410	500	820	70000014	410	500	965	70053014	410	689	1219	70324514

## Aluminium Storm Collar

Used to weather/seal the top of the flashing, supplied with a tube of silicon sealant.

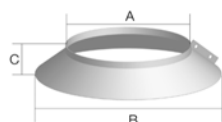

Ø	A	B	C	Code
100mm	152	255	70	70123406
130mm	177	280	70	70123407
150mm	202	301	70	70123409
180mm	227	330	70	70123410
200mm	252	351	70	70123411
250mm	302	401	70	70123412
304mm	352	451	70	70123413
355mm	402	501	70	70123414

## NOVA Stainless Storm Collar

The NOVA polished stainless steel storm collar is larger and offers a greater degree of protection from weathering. It also adds a superb looking finish to your installation.

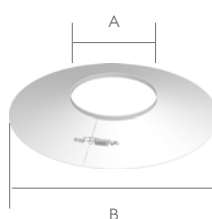

Ø	A	B	Code
100mm	151	350	4504104
130mm	181	380	4504105
150mm	201	400	4504106
180mm	231	400	4504107
200mm	251	450	4504108

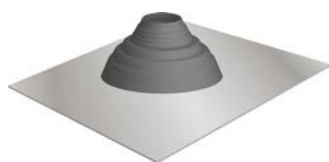

## EPDM Synthetic Rubber Flashing

The selection of the correct flashing depends on the outside chimney diameter and intended roof pitch. The table identifies which flashing should be used. Each consists of a malleable aluminium base to which an EPDM rubber cone is sealed. The cone is easily trimmed on site to suit the external diameter of the chimney. Separate installation instructions are provided with every flashing.

The EPDM flashing system will effectively seal and remain pliant over a wide range of external chimney surface temperature extremes from -30° to 115°C. The EPDM cones have also been proven to withstand intermittent surface temperatures of up to 150°C.

EPDM flashings should not be used on single wall chimney systems serving solid fuel appliances or any application where the potential surface temperature of the chimney will exceed the maximum design temperatures details above.

Ø	Ext Dia (mm)	Roof Pitch	Flashing No.	Cone Index Cut Line	Base Size (A)	Code
100mm	150	0-35°	1	E	500X500mm	4901015
130mm	180	0-40°	2	E	600x600mm	4901020
150mm	200	0-30°	2	F	600x600mm	4901020
150mm	200	0-45°	3	C	764x764mm	4901030
180mm	230	0-40°	3	D	764x764mm	4901030
200mm	250	0-35°	3	F	764x764mm	4901030
250mm	300	0-30°	3	I	764x764mm	4901030
250mm	300	0-45°	4	A	956x956mm	4901045
304mm	350	0-40°	4	C	956x956mm	4901045
355mm	400	0-35°	4	F	956x956mm	4901045

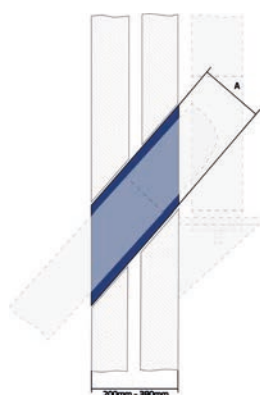

## Adjustable 45° Wall Sleeves

Used where a 135° tee is required to pass the chimney through an external masonry wall. The wall sleeve is adjustable and can be used for wall thicknesses from 200mm - 380mm. Once the desired length is determined, the joint between the telescopic sections should be sealed with aluminium backed duct tape. Also available in stainless steel. The wall sleeve offers a clearance of 25mm between the outer case of the chimney and the internal sleeve.

Ø	A	Galvanised	Stainless
100mm	250	3107104	3107304
130mm	280	3107105	3107305
150mm	300	3107106	3107306
180mm	330	3107107	3107307
200mm	350	3107108	3107308
250mm	400	3107110	3107310
304mm	450	3107112	3107312
355mm	500	3107114	3107314

*Not suitable for applications where the wall construction may contain combustible materials.*



## Trim Collar

The trim collar is a polished stainless steel circular collar with a nominal 105mm wide circular flange. This item is used to offer an aesthetic closing ring where a chimney passes through an inside / outside wall.

Ø	Code
100mm	4583204
130mm	4583205
150mm	4583206
180mm	4583207
200mm	4583208
250mm	4583210
304mm	4583212
355mm	4583214

## Angled Wall Cover Ring

The wall cover ring is designed to offer an aesthetic trim around the chimney where it penetrates a wall at an angle. This component is available in five angle variations, 0°-10°, 10°-20°, 20°-30°, 30°-40° and 40°-50°.

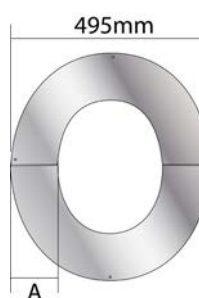

Ø	A	Wall Penetration Angle				
		0°-10°	10°-20°	20°-30°	30°-40°	40°-50°
		Code	Code	Code	Code	Code
130mm	156	7071213	7071313	7070013	7070313	7070213
150mm	146	7071215	7071315	7070015	7070315	7070215
180mm	131	7071218	7071318	7070018	7070318	7070218
200mm	121	7071220	7071320	7070020	7070320	7070220

## Locking Band



The locking band must be used on all joints and are included with each component having a female coupler.

Ø	Code
100mm	4578604
130mm	4578605
150mm	4578606
180mm	4578607
200mm	4578608
250mm	4578610
304mm	4578612
355mm	4578614

## Locking Band (Screw Toggle)



The screw-toggle locking band is provided as standard with the unbarbed female coupler on elbows and 135° tee branches.

Ø	Code
100mm	4578604MT
130mm	4578605MT
150mm	4578606MT
180mm	4578607MT
200mm	4578608MT
250mm	4578610MT
304mm	4578612MT
355mm	4578614MT

## Seal Lubricant



This must be applied around the circumference of the fitted seal to provide a lubricated interface between the seal and the liner when the product is used for positive pressure and wet applications.

	Code
250ml	3107500

Only SFL lubricant should be used as it has been specially formulated for use with both silicone and EPDM seal materials. Failure to use SFL lubricant when installing seals in NOVA product will invalidate the product warranty and potentially cause failure of the seal.

## Joint Sealing Ring (W/P1/H1)



This optional component is available for all diameters and is located in the joint groove as detailed in the Installation Instructions. This component when fitted offers condensate resistance and allows the system to operate under positive pressure conditions as detailed in Table A.

Important: SFL seal lubricating compound MUST be applied around the surface of the seal and interfacing surface prior to making the joint. It is also recommended that the seal is carefully bonded to the fixing groove prior to installation with a suitable silicon adhesive/sealant.

Ø	Code
100mm	4006310
130mm	4006313
150mm	4006315
180mm	4006318
200mm	4006320
250mm	4006325
304mm	4006430
355mm	4006435

## Joint Sealing Ring (W/P1) for 305mm and 355mm Adjustable Lengths ONLY



These seals are only to be used for the internal slip section of the 305mm and 355mm Adjustable Lengths. All other sizes utilise the standard Joint Sealing Ring as detailed above, Part No. 40063XX in the slip section.

Ø	Code
304mm	4006530
355mm	4006535

*It is important that seals are regularly inspected as part of the routine maintenance schedule. Like all types of seal, they can deteriorate over time and need replacing. To ensure many years of service, it is critical that adequate drainage is provided within the system and all near horizontal runs rise at a minimum of 3° - 5°. All seals are CE marked to 14241-1 T200 W 2 K2 I for internal applications within the flow of condensate and are corrosion tested to Class 2 for use with natural gas and kerosene. As seals are classified as sacrificial they are covered by a 2 year manufacturing defects warranty.*

SFL offer a seal fitting service at the factory, ensuring that the seals are fully bonded and cured when the products arrive on site. For further information, contact our Customer Services department.

# NOTES

# NOTES

# NOTES

# RESIDENTIAL

Vitreous Enamel

## SVIT



Quick Installation



Brand Compatibility



No Sealant Required



Year Product Warranty

**SVIT®** is a vitreous enamel-coated steel connecting flue pipe designed to facilitate the connection between a multi-fuel appliance, an existing brick chimney or a prefabricated twin wall chimney system. It offers a smooth, aesthetically pleasing joint, without the need for additional locking bands or fire cement and is available in 100mm, 125mm, 150mm, 180mm & 200mm.

Flexible Liner

## SELFLEX



V2 Corrosion Resistant



P1 / N Rating



Brand Compatibility



Year Product Warranty

**SELFLEX®** is a double skin multi-fuel flexible chimney liner suitable for multi-fuel, gas, and oil-fired applications up to a maximum flue gas temperature of 600°C. CE marked to EN 1856-2. The SELFLEX® family range is suitable for the relining of masonry flues and used with wood, multi-fuel stoves and open fires and is available in three different specifications.

Single Wall / Connecting Flue

## SIGMA



Quick Installation



Brand Compatibility



T600 Rating



Year Product Warranty

**SIGMA®** is a stainless-steel single wall connecting flue pipe for use with multi-fuel appliances, brick chimneys, twin wall systems and flexible liners. Available in four diameters 127mm, 152mm, 178mm and 203mm manufactured for wood and multi-fuel burning appliances it has a gas-tight joint that negates the need for fire cement or rope.

Twin Wall / Twist Lock

## NEXUS



127-152mm Diameter



T450 Rating



Brand Compatibility



Year Product Warranty

**NEXUS®** is the next generation of twist lock pre-fabricated chimney systems from SFL. With its clean lines and rapid installation method it's the No.1 choice for installers and discerning home owners, designed and manufactured in the UK. The Quick-Fit Jointing System offers around a 45% time saving in comparison to assembling a conventional locking band.

Insulated Flexible Liner

## TUBEX PLUS



V2 Corrosion Resistant



Brand Compatibility



125-150mm Diameter



Product Warranty

**TUBEX PLUS®** is a unique insulated flexible liner for multi-fuel applications that allows maximum flexibility and ease of installation, the insulated core offers excellent thermal resistance to maximise natural draft to ensure optimum efficiency of the appliance with its 13mm high density insulation layer. Ideal for use on modern high-efficiency wood burning and multi-fuel appliance and application.

Twin Wall / Twist Lock

## S-FLUE



T450 Rating



Brand Compatibility



127-203mm Diameter



Year Product Warranty

**S-FLUE®** is a stainless steel insulated twin wall chimney system design and manufactured in the U.K. suitable for domestic installations for a range of fuel types available in black, high thermal efficiency and an easy twist lock jointing method making it popular with installers.



# COMMERCIAL

Single Wall / Push Fit

**SUPRA**



Quick Installation



T450 / 200 Rating



80-600mm Diameter



Multi-Fuel Appliances



Year Product Warranty

**SUPRA PLUS®** is a British built single wall chimney system designed specifically for today's modern high efficiency appliances that operate under positive pressure and condensing conditions.

Manufactured in 9 diameters ranging from 80mm to 350mm and consists of a range of lengths and fittings which simply push-fit together, and which are secured with a locking band and available with a wide range of support components that cater for both lateral and vertical structural loading of the product.

**SUPRA XL®** covers larger internal diameters, 400mm, 500mm & 600mm, that can be manufactured in either 1mm or 0.6mm 316L stainless & has the same features of Supra Plus; including factory fitted seals.

Twin Wall / Twist Lock

**NOVA**



Fire Rated EN1366-13



100-600mm Diameter



P1 / H1 Rating



Year Product Warranty

**NOVA®** is a pre-fabricated, factory-made twin-wall, insulated stainless steel chimney system. Suitable for condensing and positive pressure applications and is specifically designed to meet the demands of the latest high-efficiency heating appliances as well as traditional gas and oil-fired combustion equipment. With its unique multi-barb twist-lock jointing system.

Manufactured in 8 internal diameters, ranging from 100mm to 355mm and consists of a wide range of components, together with a strong 16-barb twistlock jointing system, NOVA offers the ultimate in ease of installation and functionality. With its strong joint design, NOVA can achieve a maximum unsupported height of 3.0 metres above the last support (2.0 m for DN100), without the need for structural locking bands.

**NOVA XL®** extends the internal diameter range by a further 5 sizes, 400mm, 450mm, 500mm, 550mm & 600mm.

Twin Wall / Flanged

**EUROPA**



Fire Rated EN1366-13



T600 Rating



100-1200mm Diameter



Year Product Warranty

The **EUROPA®** product family consists of 3 flanged twin wall systems to suit a multitude of applications & all are constructed (as standard) from a 316L Stainless inner, 304 stainless outer & 25mm of insulation. All configurations are suitable for continuous flue gas temperatures up to 600C (T600) and positive pressure applications of up to 5000 Pa. The product family is for use with appliances ranging from coffee roasting machines to backup generators.

**EUROPA®** is made up of a 1mm inner & supports a diameter range from 100mm through to 1200mm; and can be configured with either 50mm or 100mm of insulation. EUROPA® is fire rated to in accordance with BS 476-24.

**EUROPA PLUS®** is made up of a 0.6mm inner & supports a diameter range from 100mm to 600mm; and can be configured with either 50mm or 100mm of insulation. Its flange joints are sealed with the use of composite graphite gaskets and U bands that offer a robust long-lived service. EUROPA PLUS® is fire rated & tested to the latest fire resistance normative BS EN 1366-13.

**EUROPA LITE®** is made up of a 0.6mm inner & supports a diameter range from 100mm through to 600mm; and can be configured with either 50mm or 100mm of insulation. Utilising a mating flanged joint design with a location spigot for easy alignment during installation

# About SFL

**British manufacturer of flues & chimneys for residential & commercial applications for more than 50 years.**

## Commercial Solutions and Project Assistance

For large-scale installations in commercial buildings, we manufacture a range of flue systems with ease of install at the centre of your design. From complex header configurations to large-diameter stacks, we can accommodate almost every requirement for any application.

At SFL, we work with carefully selected installation partners to ensure your turnkey package is carried out on time within budget by seasoned professionals.

We're committed to offering industry-leading technical support services, throughout the whole process of design, manufacture, and supply of your upcoming project. Our experienced team are on hand to assist you at every stage of your project. From initial product selection to flue routing and calculations.

## Residential Solutions

From wood burning & multi-fuel stoves to gas fires & oil boilers, our time-honoured brands of flues and chimneys have been a mainstay of domestic heating for decades. We work with a network of distribution partners providing high-quality residential flue and chimney components for easy installation. With fast delivery times and comprehensive product warranties, we ensure that your requirements are met with quality and reliability.

## SFL Head Office & Manufacturing Facility

SFL Flues & Chimneys  
Pottington Business Park  
Barnstaple  
Devon  
EX31 1LZ

Tel: +44 (0) 1271 326633  
Email: [info@sflchimneys.com](mailto:info@sflchimneys.com)  
Web: [www.sflchimneys.com](http://www.sflchimneys.com)



## At the forefront of flue and chimney manufacturing and technology.

Since 1969 SFL have been leading the way in flue and chimney innovation and technology. Our portfolio of trusted chimney and flues brands are known throughout the world for their engineering excellence. We offer industry-leading technical support services throughout the whole process of design, manufacture, and supply for commercial, domestic, and industrial applications, with uncompromised customer service.

We are proud of our British built heritage at SFL. Our manufacturing centre is based in Barnstaple, Devon, UK, alongside our extensive R&D centre, ensuring continuous product development and testing to the latest Standards.

SFL is part of the Sphering group, Sphering is an EU market maker with renowned expertise in design, manufacturing and distribution of advanced air and flue care systems.

### WeLab®

As a committed company determined to play an active role towards the environment and society, the Group has its own R&D centre: WeLab®. This facility has allowed the group to comply with the newest European standards (including the NZEB: nearly zero energy building) in terms of security and performance of appliances, but also to adopt a responsible innovation approach. With our WeLab®, we have developed test rigs based on minimum requirements in order to guarantee our clients the highest levels of security and performance.

SFL branded products are synonymous with the highest quality – it is this reputation that enables specifiers, contractors, and householders to use our products with total confidence.

NOVA®

SUPRA®

EUROPA®

S-FLUE®

NEXUS®

SVIT®

SELFLEX®

TUBEX PLUS®

IL®

SIGMA®

**Over 50 years** of industry leading experience in the flue and chimney market.



**SFL**

A Sphering Company

[www.sflchimneys.com](http://www.sflchimneys.com)



sphering-group.com



sflchimneys.com

